



INTERNATIONAL JOURNAL OF ENGINEERING SCIENCES & RESEARCH TECHNOLOGY

Analysis and Simulation of Asymmetrical Current Source Multilevel Inverter

Himanshu N Chaudhari^{*1}, Dhruva M Patel², Maulik A Chaudhari³

^{*1,2,3}Assistant professor, Department of Electrical Engineering, Snpit&Rc, Umrah, Gujarat, India
him.chaudhari@gmail.com

Abstract

This paper presents asymmetrical current source multilevel inverter approach for high power output applications. The topology used here is derived from the multilevel voltage-source inverter (MVSI) by dual conversion, this allows the wealth of existing knowledge relating to the operations, modulations and control strategies of multilevel VSI to be immediately applied to such multilevel CSI. It is based on the parallel connection of the H-bridge inverter cells using different control techniques. Simulation of asymmetrical current source multi level inverter is shown using 2 and 3 H-bridge inverter cells with parallel connection using optimization angle control technique. Now ever by the supplies which are in GP with different ratios like 2,3, etc. The proposed configuration is shown for 7,9, 15 and 27 level inverters having inherent advantages of the H-bridge multi level inverters. Structural and operational characteristics are discussed and their inherent advantages are shown. Simulation using Matlab Simulink is done to verify the performance. Simulation and results for this proposed scheme are presented in this paper.

Keywords: Asymmetrical multilevel inverter, Current source multi level inverter, MATLAB Simulink, Optimization angle control, Symmetrical multi level inverter, Total harmonic distortion (THD).

Introduction

Recently multilevel power conversion technology has been a very rapidly growing area of power electronics with good potential for further developments. The most attractive applications of this technology are in the medium to high-voltage range. Multilevel converters work more like amplitude modulation rather than pulse modulation and as a result:

- Each device in a multilevel converter has a much lower dv/dt stress.
- The outputs of the converter have almost perfect currents with very good voltage waveforms because the undesirable harmonics can be removed easily,
- The bridges of each converter work at a very low switching frequency and low speed semiconductors can be used and Switching losses are very low.

The converters that were focused upon were voltage source converters, with multilevel voltage waveforms. These converters divide the total input voltage among a number switches and allow a reduction of the voltage harmonics. As mentioned, these are the most commonly used and best-understood multilevel converters. The most multilevel converters discussed in the literature are multilevel voltage source converters. However, in many current applications,

such as shunt active filters, active power line conditioners, VAR compensations etc., we need to use multilevel current converters. This paper presents a new multilevel current converter and introduces different methods for obtaining the levels of current sources in each bridges of the multilevel current source. Then the proposed multilevel current source converter is the core of a shunt active filter, which is obtained based on this converter. The proposed new multi level current converter consists of a set of parallel single-phase full-bridge converter units. The AC current output of each levels full-bridge converter is connected in parallel such that the synthesized current waveform is the sum of the converter outputs. In other words, for high current applications, many switches can be placed in parallel, with their current summed by inductors.

However, as one of multilevel converter types, Current source Inverters (CSIs) have also some advantages such as inherent four quadrant operation capability, direct control of the output current and easier fault management for higher power applications such as high power drives. Moreover the power circuit of the CSI is simpler and more robust than the VSI due to no freewheeling diodes with unidirectional current flow. Also the CSI can provide a higher reliability related with a dc-link inductor than a capacitor for the VSI. CSIs are not as common as VSIs, an important reason for this reduced interest in CSIs is that inductors used in a CSI as storage elements have higher conduction losses and

lower energy storage efficiency compared to DC link capacitors in VSIs. But, with the development of superconducting magnetic energy storage (SMES) technologies many of the problems of conventional inductors can now be solved, and hence their applications are developing specially for higher power ratings.

Multi Level Inverter

There are two types of multi level inverter according to the current source, symmetrical type multi level inverter and asymmetrical type multi level inverter. In symmetrical type multilevel inverter all H-bridge cells are fed by equal current sources and hence all the arm cells produce similar output current steps. If all the cells are not fed by equal rating current sources the inverter becomes an asymmetrical one. In this inverter the arm cells have different effect on the output current.

The H-bridge inverter consists of power conversion cells each supplied by an isolated dc current source on the dc side, which can be obtained from batteries, fuel cells, etc. The advantage of this topology is that the modulation, control and protection requirements of each bridge are modular. It should be pointed out that, unlike the neutral point clamped and flying-inductor topologies isolated dc current sources are required for each cell in each phase. Fig. shows a three-phase topology of inverter with isolated dc-current sources. An output phase-current waveform is obtained by summing the bridges output currents.

$$I_o(t) = I_{o1}(t) + I_{o2}(t) + \dots + I_{on}(t) \dots\dots\dots (1)$$

where n is the number of parallelly connected bridges

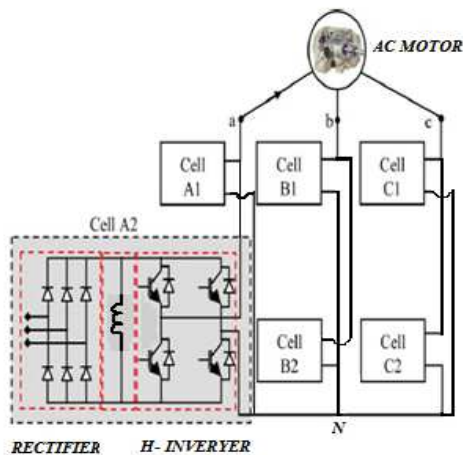

Fig:1 Structure of two cells multi level inverter

The inverter output voltage $I_o(t)$ may be determined from the individual cells switching states,

$$I_{o(t)} = \sum(\mu_j - 1) I_{dc,j}, \quad \mu_j = 0,1,\dots$$

If all dc-current sources in Fig. are equal to I_{dc} the inverter is then known as a symmetrical multilevel one. The effective number of output current levels n in symmetric multilevel inverter is related to the cells number by,

$$n = 1 + 2N$$

To provide a large number of output levels without increasing the number of bridges asymmetrical multilevel inverters can be used. It is proposed to choose the dc-current sources according to a geometric progression with a factor of 2 or 3. For N of such parallel connected inverters, one can achieve the following distinct current levels

$$n = 2^{(N+1)} - 1, \quad \text{if } I_{dc,j} = 2j - 1 I_{dc}, \quad j = 1, 2, \dots, N$$

$$n = 3^N, \quad \text{if } I_{dc,j} = 3j - 1 I_{dc}, \quad j = 1, 2, \dots, N.$$

Typical waveforms of Fig. multilevel inverter with respectively two dc current sources (I_{dc} and $2I_{dc}$) gives seven-levels output and two dc current sources I_{dc} and $3I_{dc}$ gives nine-level output.

Table 1 Comparison of multilevel inverter

	Symmetrical Inverter	Asymmetrical Inverter	
		Binary	Ternary
N	2N+1	2^{N+1}	3^N
DC source number	N	N	N
Switches number	4N	4N	4N
$I_{0MAX(pu)}$	N	$2^N - 1$	$(3^N - 1)/2$

The maximum output current of these N cascaded multilevel inverters is

$$I_{o, MAX} = \sum I_{dc, j}$$

Equation can be re written as,

$$I_{o, MAX} = (2^N - 1) I_{dc}, \quad \text{If } I_{dc,j} = 2^{j-1} I_{dc}, \quad j = 1, 2, \dots, N$$

$$I_{o, MAX} = ((2^N - 1)/2) I_{dc}, \quad \text{If } I_{dc,j} = 3^{j-1} I_{dc}, \quad j = 1, 2, \dots, N$$

Asymmetrical Current Source Multi Level Inverter

This method eliminates the excessively large number of bulky transformers required by conventional multi level inverters, the clamping diodes required by diode clamped multilevel inverters and the large no. of inductors required by flying inductor multilevel inverters. In ACMLI DC current with ratio binary (2) and ternary (3) are the most popular. In binary progression within H-Bridge inverters, the DC current having ratio 1: 2: 4: 8: . . . : 2N and the maximum current output would

be $(2^N - 1) I_{dc}$ and the current levels will be $(2^{N+1} - 1)$. While in the ternary progression the amplitude of DC currents having ratio 1: 3: 9: 27. . . : 3^N and the maximum output currents reaches to $((3^N - 1)/2) I_{dc}$ and the current levels will be (3^N) . Comparing the equations it can be seen that asymmetrical multilevel inverters can generate more current levels and higher maximum output voltages with the same number of bridges.

Control Techniques

There are many modulation techniques to control this inverter, such as Selected Harmonics Elimination or Optimized Harmonic Stepped-Waveform (OHSW), Space Vector PWM (SVPWM) and Carrier-Based PWM (CBPWM), Symmetrical step control, Optimization angle control, comparison control technique, etc.

Among other modulation optimization angle control strategies are the most popular methods used in CMLI because they are simple, efficient and easy to implement in hardware. In this method for different current levels proper firing angles are calculated from sine equation. According to the optimized firing angles output voltages are obtained from equation.

$$I = I_m \sin \phi t$$

The scheme of Optimization angle control technique for AMLI was proposed to improve the output voltage and current waveform with less THD.

Simulation and Simulation Results

The computer software package Matlab Simulink was used to implement all of the Modulation Techniques. Fig.2 shows the simulation model of 7-level and 9-level Asymmetrical multi level inverter model, which is same but the switching angles and input sources of power are different. To achieve 7 level current output, it is proposed to choose the dc-current sources according to a geometric progression with a factor of 2 and for 9 level a geometric progression with a factor 3 using two bridges.

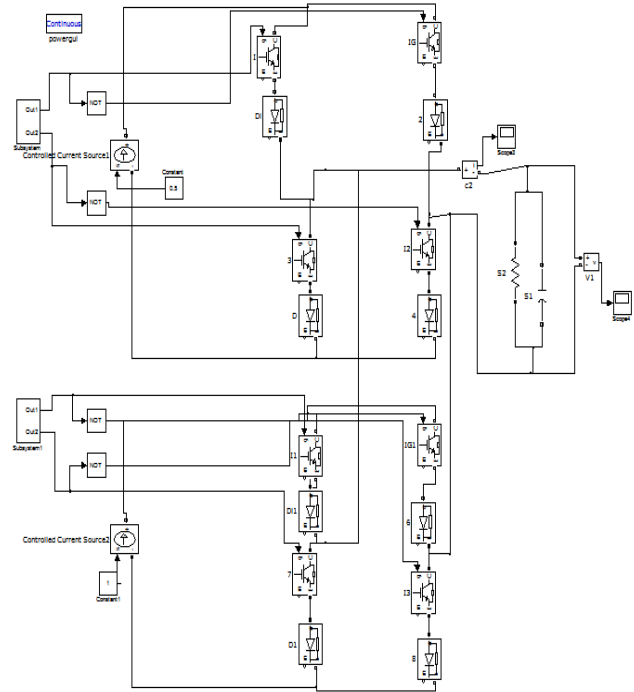

Fig.2. Simulation model for 7-level and 9-level AMLI

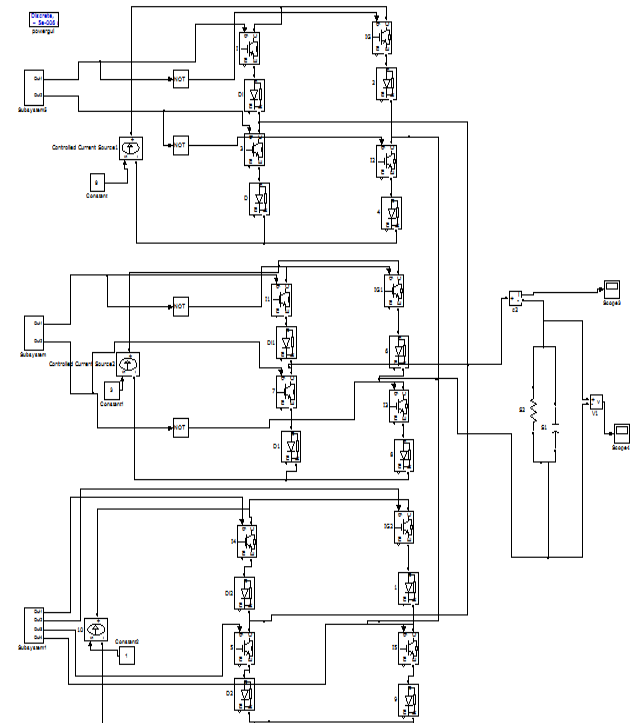

Fig.3. Simulation model for 15-level and 27-level AMLI

Fig.3 shows the simulation model of 15-level and 27-level Asymmetrical multi level inverter in that the model, which is same but the switching angles and input sources of power are different. To achieve 15 level

current output, it is proposed to choose the dc-current sources according to a geometric progression with a factor of 2 and for 27 level a geometric progression with a factor 3 using three bridges. With using same no of components we can obtained different output current levels but with different THD magnitudes. The output results with same no of bridges but with different sources are shown below.

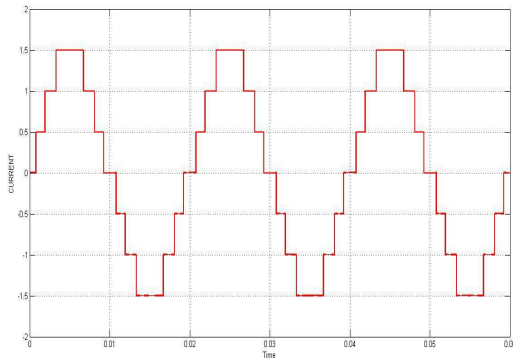

Fig. 4 7 level Output of AMLI using two bridges with binary GP ratio.

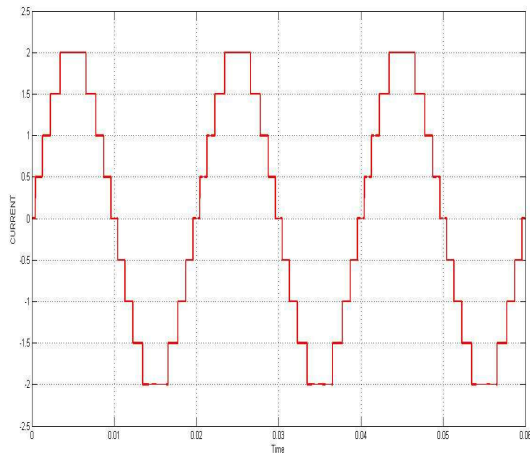

Fig.5 9level Output of AMLI using two bridges with ternary GP ratio

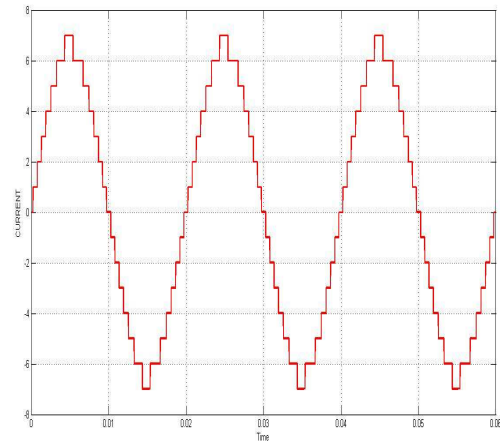

Fig. 6 15 levelOutput of ACMLI using three bridges with binary GP ratio

The THD result are summarized below obtained from the above output waveforms of the currents.

TABLE 2

Asymmetrical Types Multi Level Inverter	NO. Of Bridges	NO. of Current Levels	THD(%)With Optimum Angle Method
ACMLI with Binary ratio	2	7	14.73
	3	9	14.11
ACMLI with Ternary ratio	2	15	7.33
	3	27	4.73

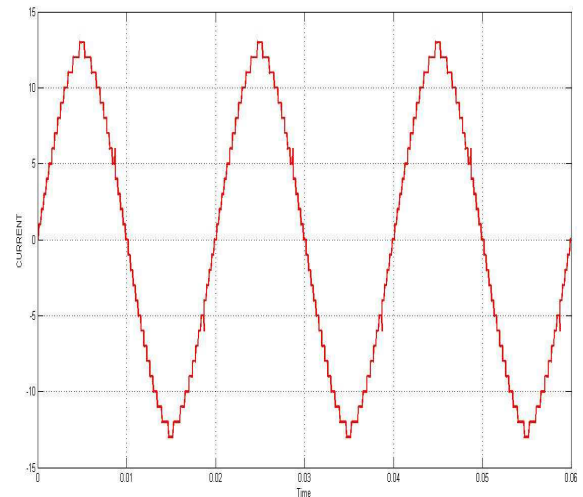

Fig. 27 Output of ACMLI using three bridges with binary GP ratio

The above results shows that as we increase the no of output levels THD reduces. For that if we want to increase the output current level to reduced the THD level using SMLI, we have to increase the no of bridges. By using four bridges and ternary voltage ratio we can have the 81 level output voltage, but more bridges increase the cost and hence their losses, and will reduce the efficiency. Further for fourth bridge DC source is 27 times the DC source voltage for the first bridge and hence bridge requires much more different power rating still have to carry the same current. Rating of the fourth bridge would be 27 times higher than rating of the first bridge and for 81 level inverter switching losses are also increased. When we use the 3 bridges THD is 3.84 with additional one bridge it reduces to 4.73 that is not a great reduction. Hence, In ACMLI use of ternary GP ratio with three bridges that is 27 level is optimum. For obtaining same no of output level SMLI is costly than the AMLI. But symmetrical type multi level inverter it is easy to control compared to AMLI. SMLI requires equal rating sources while in AMLI the rating of sources are different and must be kept according to GP ratio. THD for same no of bridges in ACMLI is less compared to SMLI is less and hence AMLI is efficient than SMLI.

Conclusion

The scheme of Optimization angle control technique for MLI was proposed to improve the output current. And it has been concluded that by increasing no. of levels for the output current, the THD can be reduced. No. of levels can be increased by increasing the no. of bridges of MLI. Further for same no. of bridges in AMLI, in ternary progression output current has more levels than binary. ACMLI are cheaper than the SCMLI and also operate at low THD levels with same no of bridges. Due to its inherent advantages ACMLI is most preferable than SMLI.

References

- [1] Bin Wu, " High-Power Converters And Ac Drives"
- [2] José Rodríguez, Jih-Sheng Lai, Fang Zheng Peng "Multilevel Inverters: A Survey of Topologies, Controls, and Applications", *IEEE Trans.*, VOL. 49, NO. 4, AUGUST 2002
- [3] Bambang Sujanarko, Mochamad Ashari "Advanced Carrier Based Pulse Width Modulation in Asymmetric Cascaded Multilevel Inverter" *International Journal of Electrical & Computer Sciences IJECS-IJENS Vol: 10 No: 06.*
- [4] Ebrahim Babaei and Gevorg B. Gharehpetian, " A New Topology for Multilevel Current Source Converters" *2 ECTI TRANSACTIONS ON ELECTRICAL ENG., ELECTRONICS, AND COMMUNICATIONS VOL.4, NO.1 FEBRUARY 2006*
- [5] Mariusz Malinowski, K. Gopakumar, Jose Rodriguez and Marcelo A. Pérez, " A Survey on Cascaded Multilevel Inverters" *Ieee Transactions On Industrial Electronics*, Vol. 57, No. 7, July 2010
- [6] Tiantong Hu, Shouhua Bai, " Research On The Topology that Based on An Asymmetrical Multi-level Inverters" 978-1-4244-7161-4/10/\$26.00 ©2010 IEEE
- [7] Juan Dixon, Javier Pereda "Asymmetrical Multilevel Inverter for Traction Drives Using Only One DC Supply" *IEEE Transactions On Vehicular Technology*, Vol. 59, No. 8, October 2010
- [8] Tiantong Hu, Shouhua Bai " Research On The Topology that Based on An Asymmetrical Multi-level Inverters" 978-1-4244-7161-4/10/\$26.00 ©2010 IEEE
- [9] B.Urmila, D.Subbarayudu, " Multilevel Inverters: A Comparative Study of Pulse Width Modulation Techniques" *International Journal of Scientific & Engineering Research*, Volume 1, Issue 3, December-2010
- [10] Jianyu Bao, Weibing Bao, Jie Gong, " A PWM Multilevel Current-Source Inverter Used for Grid Connected Wind Energy Conversion System", *2012 International Conference on Future Energy, Environment, and Materials.*